



Vibration sensor

VIM62PL-E0G10-0ME-I420K24

- Extended temperature range
- Screw-in thread for simple installation
- Simple electrical commissioning
- Vibration acceleration in g via root mean square formation (rms)
- Detection of low frequency vibrations

Vibration sensor with analog current output and increased temperature resistance



Function

The vibration sensor determines the vibration variable with the aid of rms (root mean square) averaging. This form of quadratic averaging or pre-filtering allows precise trend statements to be made about the condition of the application. The vibration sensor also impresses with its strong robustness against environmental influences. A stainless steel housing provides optimum protection against corrosion. The wide temperature range provides reliable measured values despite harsh conditions. The simple mounting facilitates commissioning in any application.

Dimensions

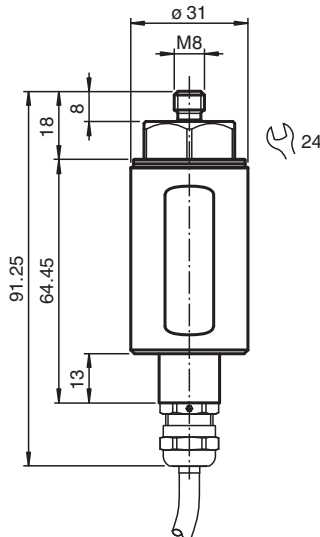

Technical Data

General specifications

Type	Vibration sensor
Measuring technology	MEMS
Series	Performance Line

Release date: 2021-11-30 Date of issue: 2021-11-30 Filename: 70141166-100004_eng.pdf

Refer to "General Notes Relating to Pepperl+Fuchs Product Information".

Pepperl+Fuchs Group
www.pepperl-fuchs.com

USA: +1 330 486 0001
fa-info@us.pepperl-fuchs.com

Germany: +49 621 776 1111
fa-info@de.pepperl-fuchs.com

Singapore: +65 6779 9091
fa-info@sg.pepperl-fuchs.com

PF PEPPERL+FUCHS

Technical Data

Measured variable		Vibration acceleration
Measurement range		
Vibration acceleration	a-rms	0 ... 10 g rms
Measurement accuracy		± 0.01 g (calibration point: 90% of the measuring range; 159.2 Hz) Complies with the tolerance requirements of DIN ISO 2954
Cross-sensitivity		< 5 % of the partial lateral acceleration, which acts exactly 90° to the measuring axis
Frequency range		1 ... 1000 Hz
Averaging time		for a-rms: 12 s
Electrical specifications		
Fusing		fuse unit 3 A , semi-time-lag , 30 V DC
Operating voltage	U _B	10 ... 30 V DC
Current consumption		max. 25 mA
Power consumption	P ₀	max. 750 mW
Time delay before availability	t _v	10 s (rms filter is calculated initially with measurement data before they are available at the output)
Surge protection		up to 2 kV
Analog output		
Output type		current output 4 ... 20 mA
Load resistor		500 Ω
Short-circuit protection		yes
Standard conformity		
Degree of protection		DIN EN 60529, IP66, IP67
Shock resistance		DIN EN 60068-2-27, 60 g, 6 ms
Vibration resistance		DIN EN 60068-2-6, 16.5 g, 10 ... 1000 Hz
Ambient conditions		
Ambient temperature		-40 ... 60 °C (-40 ... 140 °F)
Measuring head temperature		-40 ... 125 °C (-40 ... 257 °F) directly at the mounting point
Storage temperature		-40 ... 60 °C (-40 ... 140 °F)
Mechanical specifications		
Connection type		cable
Housing material		Stainless steel 1.4305 / AISI 303
Housing length		91.25 mm
Housing diameter		31 mm
Degree of protection		IP66/IP67
Cable		
Number of cores		4
Core cross section		0.34 mm ²
Length	L	2 m
Tension force		max. 80 N (tensile loading directly at the cable, not at the metal conduit if attached)
Mass		approx. 200 g

Connection

