



Model Number

AVS58-H

Features

- Industrial standard housing Ø58 mm
- 16 Bit singleturn
- Hardware encoder
- Data transfer up to 2 Mbaud
- Optically isolated RS 422 interface
- Servo or clamping flange
- Up to 4096 pulses on incremental track

Description

This singleturn absolute encoder with modern fast technology transmits a position value corresponding to the shaft setting via the SSI interface (Synchronous Serial Interface). The resolution of the AVS58-H is maximum 65536 steps per revolution. In contrast to the AVS58 series the encoder does not have a microcontroller. Thus, it is a pure hardware encoder.

The control module sends a clock bundle to the absolute encoder to obtain the position data. The rotary encoder then sends the position data synchronous to the cycles of the control module. It is possible to select the counting direction with the function input.

This singleturn absolute encoder is available either in clamp flange design with a shaft diameter of 10 mm x 20 mm or in a servo flange design with a shaft diameter of 6 mm x 10 mm. The electrical connection is made by a 12-pin round plug connector. It is also possible to obtain a version with a 1 m cable connector.

Technical data

General specifications

Detection type	photoelectric sampling
Device type	Singleturn absolute encoder

Functional safety related parameters

MTTF _d	170 a
Mission Time (T _M)	20 a
L _{10h}	1.9 E+11 at 6000 rpm and 20/40 N axial/radial shaft load
Diagnostic Coverage (DC)	0 %

Electrical specifications

Operating voltage U _B	4.5 ... 30 V DC (SSI, SSI + RS422) ; 10 ... 30 V DC (SSI + Push/Pull)
No-load supply current I ₀	max. 180 mA
Time delay before availability t _v	< 250 ms
Linearity	± 2 LSB at 16 Bit, ± 1 LSB at 13 Bit, ± 0,5 LSB at 12 Bit
Output code	Gray code, binary code
Code course (counting direction)	cw descending (clockwise rotation, code course descending)

Interface

Interface type	SSI ; SSI + incremental track
Monoflop time	20 ± 10 µs

Resolution

Single turn	up to 16 Bit
Overall resolution	up to 16 Bit
Transfer rate	0.1 ... 2 MBit/s
Voltage drop	U _B - 2.5 V
Standard conformity	RS 422

Input 1

Input type	Selection of counting direction (cw/ccw)
Signal voltage	
High	4.5 ... 30 V
Low	0 ... 2 V
Input current	< 6 mA
Switch-on delay	< 10 ms

Output

Output type	RS422, Push/Pull
Signal output	A+B+/A+/B
Pulses	1024, 2048, 4096

Connection

Connector	type 9416 (M23), 12-pin, type 9416L (M23), 12-pin
Cable	Ø7 mm, 6 x 2 x 0.14 mm ² , 1 m

Standard conformity

Degree of protection	DIN EN 60529, IP65 (without shaft seal) ; DIN EN 60529, IP66/IP67 (with shaft seal)
Climatic testing	DIN EN 60068-2-3, no moisture condensation
Emitted interference	DIN EN 61000-6-4
Noise immunity	DIN EN 61000-6-2
Shock resistance	DIN EN 60068-2-27, 100 g, 6 ms
Vibration resistance	DIN EN 60068-2-6, 20 g, 10 ... 2000 Hz

Ambient conditions

Operating temperature	-40 ... 85 °C (-40 ... 185 °F)
Storage temperature	-40 ... 85 °C (-40 ... 185 °F)

Mechanical specifications

Material	
Combination 1	housing: powder coated aluminum flange: aluminum shaft: stainless steel
Combination 2 (Inox)	housing: stainless steel flange: stainless steel shaft: stainless steel
Mass	approx. 460 g (combination 1) approx. 800 g (combination 2)
Rotational speed	max. 12000 min ⁻¹
Moment of inertia	50 gcm ²
Starting torque	< 5 Ncm
Shaft load	
Axial	40 N
Radial	110 N

Approvals and certificates

UL approval	cULus Listed, General Purpose, Class 2 Power Source
-------------	---

Dimensions

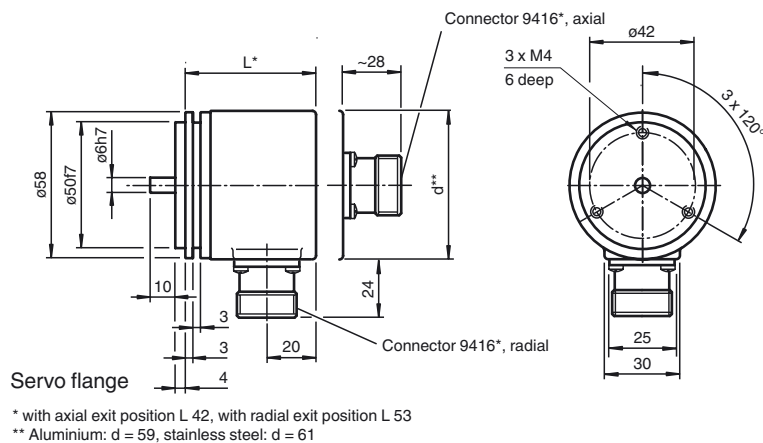
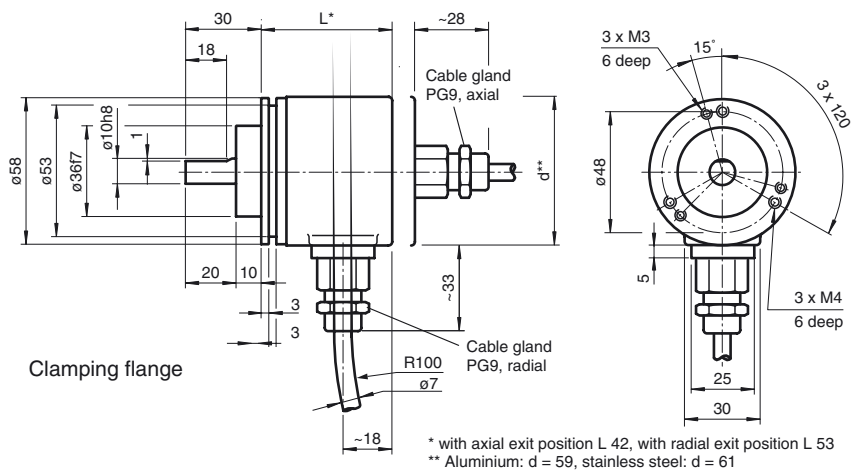
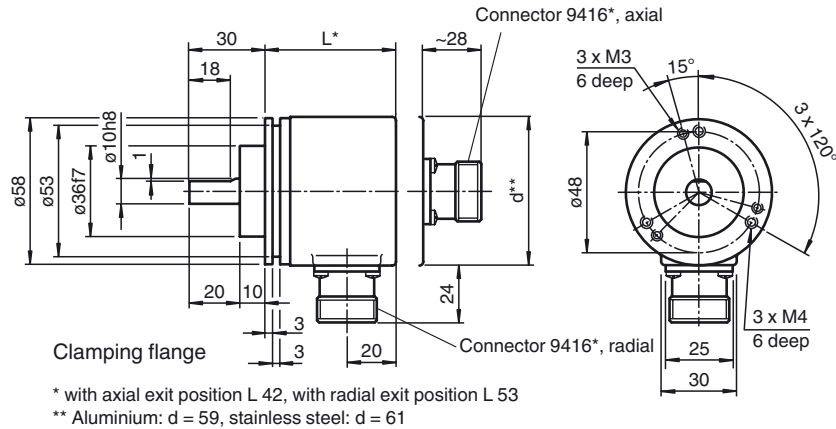

Release date: 2016-07-12 16:13 Date of issue: 2016-07-12 149176_eng.xml

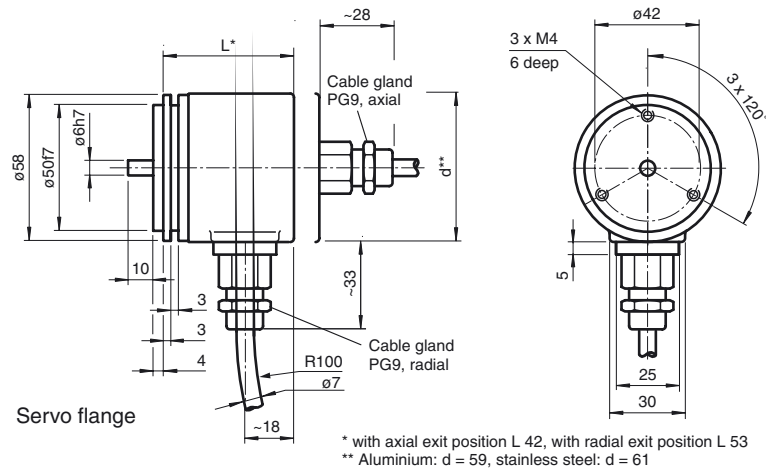

Release date: 2016-07-12 16:13 Date of issue: 2016-07-12 149176_eng.xml

Refer to "General Notes Relating to Pepperl+Fuchs Product Information".

Pepperl+Fuchs Group
www.pepperl-fuchs.com

USA: +1 330 486 0001
fa-info@us.pepperl-fuchs.com

Germany: +49 621 776 4411
fa-info@de.pepperl-fuchs.com

Singapore: +65 6779 9091
fa-info@sg.pepperl-fuchs.com

Electrical connection

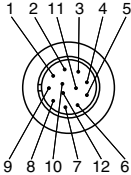
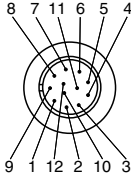
Signal	Cable Ø7 mm, 12-core	Connector 9416, 12-pin	Connector 9416L, 12-pin	Explanation
GND (encoder)	White	1	1	Power supply
U _b (encoder)	Brown	2	8	Power supply
Clock (+)	Green	3	3	Positive cycle line
Clock (-)	Yellow	4	11	Negative cycle line
Data (+)	Grey	5	2	Positive transmission data
Data (-)	Pink	6	10	Negative transmission data
A	Blue	7	12	Incremental track A
V/R	Red	8	5	Input for selection of counting direction
Reserved	Black	9	9	Not wired, reserved
B	Violet	10	4	Incremental track B
A	Grey/Pink	11	6	Incremental track \bar{A}
B	Red/Blue	12	7	Incremental track \bar{B}
				

Release date: 2016-07-12 16:13 Date of issue: 2016-07-12 149176_eng.xml

Description

The Synchronous Serial Interface was specially developed for transferring the output data of an absolute encoder to a control device. The control module sends a clock bundle and the absolute encoder responds with the position value. Thus only 4 lines are required for the clock and data, no matter what the resolution of the rotary encoder is. The RS 422 interface is optically isolated from the power supply.

SSI signal course Standard

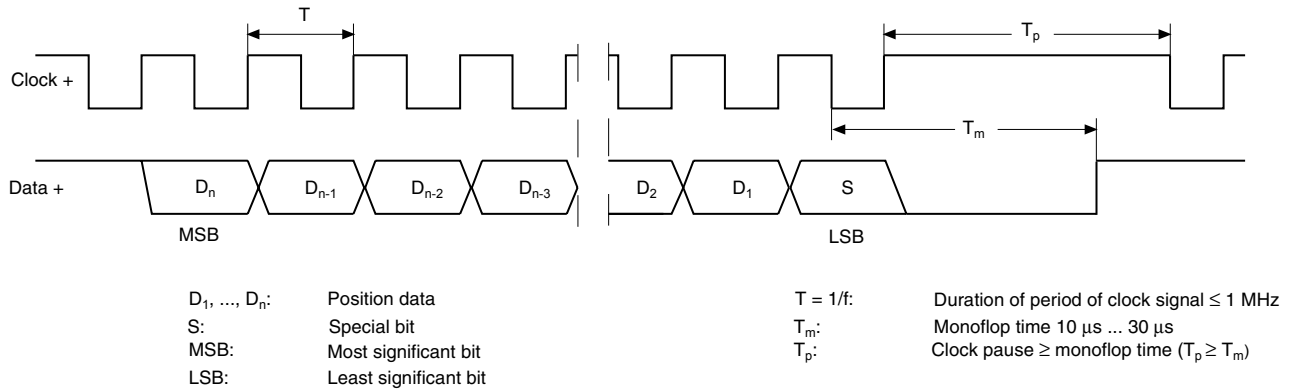

SSI output format Standard

- At idle status signal lines "Data +" and "Clock +" are at high level (5 V).
- The first time the clock signal switches from high to low, the data transfer in which the current information (position data (D_n) and special bit (S)) is stored in the encoder is introduced.
- The highest order bit (MSB) is applied to the serial data output of the encoder with the first rising pulse edge.
- The next successive lower order bit is transferred with each following rising pulse edge.
- After the lowest order bit (LSB) has been transferred the data line switches to low until the monoflop time T_m has expired.
- No subsequent data transfer can be started until the data line switches to high again or the time for the clock pause T_p has expired.
- After the clock sequence is complete, the monoflop time T_m is triggered with the last falling pulse edge.
- The monoflop time T_m determines the lowest transmission frequency.

SSI output format ring slide operation (multiple transmission)

- In ring slide operation, multiple transmission of the same data word over the SSI interface makes it possible to offer the possibility of detecting transmission errors.
- In multiple transmission, 25 bits are transferred per data word in standard format.
- If the clock change is not interrupted after the last falling pulse edge, ring slide operation automatically becomes active. This means that the information that was stored at the time of the first clock change is generated again.
- After the first transmission, the 26th pulse controls data repetition. If the 26th pulse follows after an amount of time greater than the monoflop time T_m, a new current data word will be transmitted with the following pulses.



If the pulse line is exchanged, the data word is generated offset. Ring slide operation is possible up to max. 13 bits.

Block diagram

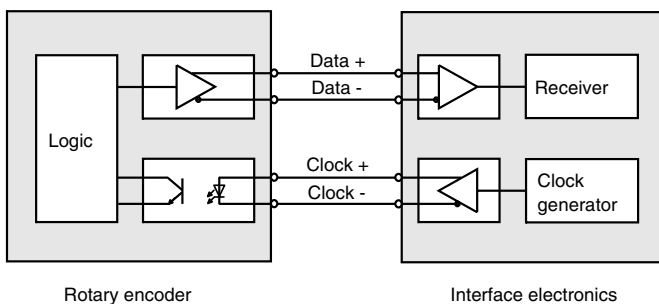

Line length

Line length in m	Baudrate in kHz
< 50	< 400
< 100	< 300
< 200	< 200
< 400	< 100

Release date: 2016-07-12 16:13 Date of issue: 2016-07-12 149176_eng.xml

Signal outputs

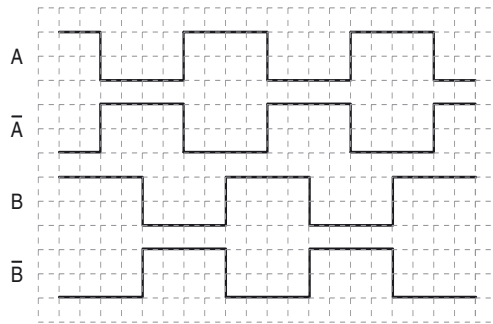

↻ cw - with view onto the shaft

Input

The selection of the counting direction input (V/R) is activated with 0-level.

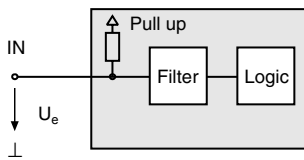

Accessories

For type	Accessories	Name/defining feature	Order code		
AVS58*-011	Couplings	D1: Ø10 mm, D2: Ø10 mm	9401		
		D1: Ø10 mm, D2: Ø10 mm	9404		
		D1: Ø10 mm, D2: Ø10 mm	9409		
		D1: Ø10 mm, D2: Ø10 mm	KW		
	Measurement wheels with circumference of 500 mm	Plastic	9101, 10		
		Pimpled rubber	9102, 10		
		Knurled aluminium	9103, 10		
		Knurled plastic	9112, 10		
	Measurement wheels with circumference of 200 mm	Plastic	9108, 10		
		Pimpled rubber	9109, 10		
		Knurled aluminium	9110, 10		
	Mounting aids	Knurled plastic	9113, 10		
		Mounting bracket	9203		
	AVS58*-032	Couplings	Mounting bracket	9213	
D1: Ø6 mm, D2: Ø6 mm			9401		
D1: Ø6 mm, D2: Ø6 mm			9402		
D1: Ø6 mm, D2: Ø6 mm			9404		
D1: Ø6 mm, D2: Ø6 mm			9409		
Mounting aids		D1: Ø6 mm, D2: Ø6 mm	KW		
		Mounting bracket and set	9300 and 9311-3		
		Eccentric clamping elements	9310-3		
		All	Connectors	Cable socket	9416
				Cable socket	9416L

For additional information on the accessories, please see the "Accessories" section.

Order code



Number of bits singleturn

- 12 4096 (standard)
- 13 8192
- 16 65536

Options

- 1 Incremental track 1024 pulses, Push/Pull
- 2 Incremental track 2048 pulses, Push/Pull
- 3 Incremental track 4096 pulses, Push/Pull
- 4 Incremental track 1024 pulses, RS422
- 5 Incremental track 2048 pulses, RS422
- 6 Incremental track 4096 pulses, RS422

Output code

- B Binary
- G Gray

Exit position

- A Axial
- R Radial

Connection type

- K1 Cable Ø7 mm, 6 x 2 x 0.14 mm², 1 m
- AA Plug connector type 9416, 12-pin
- AB Plug connector type 9416L, 12-pin

Shaft dimension/flange version

- 011 Shaft Ø10 mm x 20 mm with clamping flange
- 032 Shaft Ø6 mm x 10 mm with servo flange

Housing material

- N Aluminium, powder coated
- I Inox*

Principle of operation

- S Singleturn

Shaft version

- V Solid shaft

Data format

- A SSI (Synchronous Serial Interface)

*Housing material I only available with axial exit position.